



# Policy for a Circular Plastic Economy in the Northwest European (NWE) Region

*An Overview and Good Practices*

# Policy for a Circular Plastic Economy in the Northwest European (NWE) Region

## *An Overview and Good Practices*

**THIS DOCUMENT COMBINES FOUR REPORTS ON EXISTING REGIONAL BUSINESS SUPPORT PROGRAMMES FOR INCLUSION OR UNDERSTANDING OF CIRCULAR ECONOMY (CE) OBJECTIVES, DELIVERABLE DT3.1.2 FROM THE TRANSFORM-CE PROJECT. BESIDES A GENERAL OVERVIEW ON NATIONAL AND REGIONAL LEVEL, THE FOCUS IS ON A SELECTION OF NATIONAL AND REGIONAL PROGRAMMES AIMED AT THE PLASTICS INDUSTRY. AFTER EXPLAINING THE FORMAT TO STRUCTURE THE PROGRAMMES, THE RESULTS FOR THE FOUR REGIONS ARE PRESENTED: GREATER MANCHESTER (UK), RHINELAND PALATINATE AND NORTHRHINE WESTFALIA (DE), WALLONIA (BE), CENTRAL NETHERLANDS (NL). THE DOCUMENT ENDS WITH A SHORT CONCLUSION.**

**Date** December 2020

**Authors** Evert-Jan Velzing, Malou van der Vegt, Martijn Rietbergen, Ulrike Kirschnick, Hjalka Biernat, Olivier Talon, Soumaya Lafqir, Russell Yates

**Deliverable** WPT3 D1.2 Existing business support instruments for a Circular Economy in the NWE-region



This research has been conducted as part of the TRANSFORM-CE project. More information about the project can be found on: [www.nweurope.eu/transform-ce](http://www.nweurope.eu/transform-ce). TRANSFORM-CE is supported by the Interreg North West Europe programme as part of the European Regional Development Fund (ERDF).

## Table of contents

<b>1. Introduction</b>	<b>4</b>
1.1 Towards a circular economy for plastics	4
1.2 Four regions in four countries	5
1.3 Objective of this report	6
<b>2. Approach to study circular economy policy programmes</b>	<b>7</b>
<b>3. Regional reports and best practices</b>	<b>9</b>
<b>4. Wallonia, Belgium</b>	<b>10</b>
4.1 Best Practice 1 – Challenge “Plastics Go Green and Circular”	12
4.2 Best Practice 2 – Yara, Tertre	12
4.3 Best Practice 3 – Circular Economy Facilitator	14
<b>5. Germany with a focus on Rhineland Palatinate and Northrhine Westfalia</b>	<b>15</b>
5.1 Best Practice 1 – Production-integrated environmental protection (PIUS)	17
5.2 Best Practice 2 – Green public procurement of recycled plastics	18
5.3 Best Practice 3 – Voluntary return system of plastic profile manufacturers	19
<b>6. Central Netherlands</b>	<b>21</b>
6.1 Best Practice 1 – Circular plastic factory	23
6.2 Best Practice 2 – Circular City Bin	23
6.3 Best Practice 3 – Platform Circular Flevoland	24
<b>7. Greater Manchester, UK</b>	<b>26</b>
7.1 Best practice 1 – Additive Manufacturing Pilot Plant	29
7.2 Best Practice 2 – North West of England Circular Economy Hub	30
7.3 Best Practice 3 – Plastic to Hydrogen Facility, Protos	30
<b>8. Conclusion</b>	<b>31</b>
<b>References</b>	<b>32</b>

## 1. Introduction

In recent years attention for sustainable development has been paramount in industry and innovation policy of many countries and regions. Although in many cases the development to a sustainable innovation policy is still muddling through, a different direction can be clearly seen. The European Commission has been discussing societal challenges and a mission-oriented approach to research and innovation, that should help solve grand challenges.<sup>1</sup> This and other initiatives cumulated in the *EU Green Deal*, presented by the end of 2019.<sup>2</sup> On a national level for example the Netherlands also developed a mission-oriented innovation policy, sometimes existing next to traditional instruments that are still in place.<sup>3</sup>

These policy changes and more are needed, because traditional innovation policy does not meet the systemic and comprehensive approach needed for developing (sustainable) innovation systems.<sup>4</sup> Because of specific characteristics of different industries, it is necessary to develop differing approaches, keeping in mind relevant general policy towards a circular economy. Hence, several programmes to invest in specific sectors or subjects have started, such as building & construction, energy, ICT and food.<sup>5</sup> One of these projects is the TRANSFORM-CE project, focussing on the plastics industry. This report lies at the basis of this project, that aims at transforming single use plastic and creating a circular economy business model.<sup>6</sup>

### 1.1 Towards a circular economy for plastics

Currently, European waste management approaches are not resource efficient. This leads to the worrying fact that much pre-segregated and mixed waste plastics end up in landfill and/or energy from waste (EfW). As stated in the TRANSFORM-CE project proposal<sup>7</sup> the European Commission aims to ensure all plastic packaging is recyclable by 2030. The *European Strategy for Plastic in a Circular Economy* sets out the vision for a circular plastics economy.<sup>8</sup> In this strategy, the European Commission envisions major changes by 2030. These challenges are seen as an opportunity for the European industry in terms of innovation, growth and jobs. Furthermore, the benefits in terms of a cleaner and safer environment are stressed.

---

<sup>1</sup> Mazzucato, M. (2018). *Mission-Oriented Research & Innovation in the European Union – A problem-solving approach to fuel innovation-led growth*. Available from: [https://ec.europa.eu/info/sites/info/files/mazzucato\\_report\\_2018.pdf](https://ec.europa.eu/info/sites/info/files/mazzucato_report_2018.pdf) [Accessed 3 February 2020],

<sup>2</sup> EC. (2019). *The European Green Deal*. European Commission. Available from: <https://eur-lex.europa.eu/legal-content/EN/TXT/?qid=1576150542719&uri=COM%3A2019%3A640%3AFIN> [Accessed 3 February 2020].

<sup>3</sup> Knol, E. & Velzing, E-J. (2019). *Learning communities for MMIP's – Een schakel voor versnelling en opschaling*. Ommen: Bureau Qeam.

<sup>4</sup> Velzing, E-J. (2013). *Innovatiepolitiek*. Delft: Eburon. Frenken, K. & Hekkert, M.P. (2017). *Innovatiebeleid in tijden van maatschappelijke uitdagingen. Essaybundel "Sturen in een verweven dynamiek" - Perspectieven op complexiteit en oriëntaties voor beleid* (pp. 46-57). Den Haag: Ministerie van Economische Zaken.

<sup>5</sup> For more information see for example <https://www.nweurope.eu/projects/project-search/> or <https://www.interregeurope.eu/projects/>

<sup>6</sup> For more information please visit: <https://www.nweurope.eu/projects/project-search/transform-ce-transforming-single-use-plastic-waste-into-additive-manufacturing-and-intrusion-extrusion-moulding-feedstocks-and-creating-a-new-circular-economy-model-for-nwe/>

<sup>7</sup> TRANSFORM-CE. (2019). *INTERREG NWE project proposal - TRANSFORMing single use plastic waste into additive manufacturing and intrusion-extrusion moulding feedstocks and creating a new Circular Economy model for NWE*.

<sup>8</sup> EC. (2018). *A European Strategy for Plastics in a Circular Economy*. Brussels: European Commission.

More specific, the European Commission defines three major 'ways forward'.<sup>9</sup> The first aim is to improve the economics and quality of plastics recycling. To accomplish this more 'design for circularity' is essential, the demand for recycled plastics has to be improved and better and more harmonised separate collection and sorting is needed. Secondly, less plastic waste and littering should be accomplished. And thirdly, innovation and investment towards circular solutions have to be promoted.

The goals of the TRANSFORM-CE project are in line with these objectives from the European Commission. In the project proposal this was written down as: "The challenge which TRANSFORM-CE seeks to address is increased business engagement to ensure uptake of recycled single use plastics (SUP) into new and existing products, to stimulate market demand for consumers and to create a circular approach where businesses adopt new circular business models using tried and tested technical processes."

## 1.2 Four regions in four countries

Next to these supranational objectives, countries have developed policies on how to stimulate a circular economy for plastics. In this project and in this report the focus is on four regions: Wallonia (Belgium), Rhineland Palatinate and Northrhine Westfalia (Germany), Central Netherlands (the Netherlands) and Greater Manchester (UK). At a national and regional level the following objectives are in line with those of the European Union:

- **Belgium:** Wallonia Regional Government (2019) is investing 120 M€ in 6 new plastic recycling treatment plants to enable the re-purposing of packaging and electronic equipment and offers several types of support for circular initiatives (cf. below). The Walloon plan for waste-resources (PWD-R) targets (2025 vs. 2013) an 8% reduction of household packaging waste and a rise of P+MC sorting from 48% to 73%. The Walloon parliament voted in May 2019 a resolution<sup>10</sup> about the support towards a circular economy, with few concrete indicators but a targeted 80% of products on the Walloon market that should be repairable and/or recyclable by 2040.
- **Germany:** Within the Top 3 leading nations globally for recycling providing leverage to dissemination across national, regional and NWE level. Its national packaging law sets ambitious target to reach 63% recycling by 2022 on all plastic packaging.
- **the Netherlands:** The Dutch national government aims to half the use of raw materials by 2030, to achieve a full CE by 2050.<sup>11</sup> For the short term this policy objective has been worked out in a CE Implementation Programme.<sup>12</sup> To support the ambition, a consortium of the

---

<sup>9</sup> See chapter 4 from EC. (2018). *A European Strategy for Plastics in a Circular Economy*. Brussels: European Commission.

<sup>10</sup> [http://nautilus.parlement-wallon.be/Archives/2018\\_2019/RES/1330\\_3.pdf](http://nautilus.parlement-wallon.be/Archives/2018_2019/RES/1330_3.pdf)

<sup>11</sup> MinIM & MinEZ. (2016). *Nederland Circulair in 2050*. Retrieved from:

<https://www.rijksoverheid.nl/onderwerpen/circulaire-economie/documenten/rapporten/2016/09/14/bijlage-1-nederland-circulair-in-2050>

<sup>12</sup> MinIM & MinEZ, (2019). *Uitvoeringsprogramma Circulaire Economie 2019-2023*. Retrieved from:

<https://www.rijksoverheid.nl/onderwerpen/circulaire-economie/documenten/rapporten/2019/02/08/uitvoeringsprogramma-2019-2023>

national government and more than 70 businesses and environmental organisations signed the Plastic Pact NL.<sup>13</sup>

- **United Kingdom:** The UK Plastic Pact<sup>14</sup> led by WRAP and the Ellen MacArthur Foundation focuses on increasing the recycled content of packaging by 30% reducing SUP by along with other targets by 2025. The UK 25 Year Environment Plan also sets out commitments on waste reduction and SUP. Greater Manchester aims to become the first UK city region to remove SUP by 2020 as part of a 5 year Environment Plan.

### 1.3 Objective of this report

This document combines four studies on existing regional business support programmes for inclusion or understanding of circular economy (CE) objectives.<sup>15</sup> Besides a general overview on national and regional level, the focus is on a selection of policy programmes aimed at stimulating circular economy for the plastics industry. After explaining the format to structure the programmes in the next chapter, the results for the four regions are presented in chapter 3. The report ends with a concise overall conclusion on the regional policy and lessons from the selected best practices.

---

<sup>13</sup> See: <https://www.rijksoverheid.nl/documenten/kamerstukken/2019/02/20/plastic-pact-nl>

<sup>14</sup> <https://www.newplasticseconomy.org/news/uk-plastics-pact-launched-by-the-ellen-macarthur-foundation-and-wrap>

<sup>15</sup> Deliverable DT3.1.2 from the Transform-CE project.



## 2. Approach to study circular economy policy programmes

An important stimulus for transitioning towards a circular economy is coming from regional, national and supranational governmental organisation. In order to give suggestions to policy makers, we need to understand what is currently happening. For that reason we made an inventory of existing business support programmes for inclusion or understanding of circular economy objectives, in the regions and cities involved in the TRANSFORM-CE project:

- Greater Manchester Combined Authority (UK),
- Rhineland Palatinate and Northrhine Westfalia (Germany),
- Wallonia (Belgium), and
- Central Netherlands (the Netherlands).

Traditionally governments stimulate and influence companies by innovation policy, these are measures from public organisations that influence, and in many cases try to stimulate, innovation by companies.<sup>16</sup> Since innovation and innovation policy include many different activities, a model for a more simplified overview is helpful. In general three categories can be distinguished when assessing policy instruments: 1) regulatory instruments, 2) economic and financial instruments, and 3) soft instruments.<sup>17</sup> In their study on policy instruments Borrás and Edquist define these types as follows:

1. Regulatory instruments are “legal tools for the regulation of social and market interactions”, which includes laws, rules and directives.
  - Examples: Intellectual property rights; waste regulation; procurement regulation.
2. Economic and financial instruments are “specific pecuniary incentives (or disincentives) and support specific social and economic activities”.
  - Examples: research funding; CO<sub>2</sub> tax; tax incentives
3. Soft instruments are voluntary and non-coercive stimuli.
  - Examples: Public-private partnerships; codes of conduct; voluntary agreements; information.

To further specify policy instruments, for this project a distinction is made between three purposes: technology push, demand pull and aiming at a systemic level.<sup>18</sup> This leads to the following template for inventorying business support programmes that is being used to typify the examples to support circular economy investments in this report (see table 1).

---

<sup>16</sup> See for example: Borrás, S. & Edquist, C. (2013). The choice of innovation policy instruments. *Technological Forecasting & Social Change*, 8, pp. 1513-1522. Velzing, E-J. (2013). *Innovatiepolitiek*. Delft: Eburon.

<sup>17</sup> Borrás, S. & Edquist, C. (2013).

<sup>18</sup> See for a similar approach: Rogge, K. S., & Reichardt, K. (2016). Policy mixes for sustainability transitions: An extended concept and framework for analysis. *Research Policy*. <https://doi.org/10.1016/j.respol.2016.04.004>.

**Table 1:** *Template for existing CE business support programmes*

<b>Policy instrument</b>	<b>Area</b>	<b>Target groups</b>	<b>Policy type</b>	<b>Purpose</b>
Name	country, region, city/municipality	enterprises; SME; start-ups; education; knowledge institutes; consumers	regulatory; economic or financial; soft instruments	technology push; demand pull; systemic

This report combines an analysis of four regions. In the following chapter for each region general characteristics are described, policy stakeholders, circular economy (plastics) objectives and budget. Subsequently, examples of best practices are presented, for which characteristics of the support programme, objectives, results and lessons learned are summarised.



### 3. Regional reports and best practices

For each region/country, three best practices will be selected. An overview of these best practices is given in table 2. In the country reports below these best practices are showcased and further elaborated on in the following order: Wallonia, Belgium (chapter 4); Rhineland Palatinate and Northrhine Westfalia, Germany (chapter 5); Central Netherlands (Flevoland, Utrecht) (chapter 6); Greater Manchester Combined Authority, United Kingdom (chapter 7).

**Table 2:** Overview of best practices

<b>Policy instrument</b>	<b>Area</b>	<b>Target groups</b>	<b>Policy type</b>	<b>Purpose</b>
<b>Challenge “Plastics Go Green and Circular”</b>	BE	SME and start-ups	economic	Technology push
<b>Yara, industrial synergy example</b>	Tertre, BE	enterprises	Soft instrument	Systemic, Technology push
<b>Circular Economy Agent by Forem</b>	Mons, BE	Education	Soft Instrument	Systemic
<b>Financial support programme “Production-integrated environmental protection” (PIUS)</b>	DE Especially federal states NRW, RLP, Hesse and BaWü	Enterprises, SMEs, consultants for energy and resource efficiency	Financial instrument	Systemic, Technology push
<b>Green public procurement</b>	DE with City Münster as one example	Enterprises, consumers	Regulatory instrument	Demand pull
<b>Voluntary return system of window producers</b>	DE	Enterprises, consumers	Soft instrument	Systemic
<b>Circular Plastic Factory (Circulaire Plasticfabriek)</b>	Almere, NL	Enterprises, SME, start-ups	Soft instrument	Technology push
<b>Circular City Bin</b>	City of Utrecht, NL	Enterprises, SME	Regulatory instrument	Demand pull
<b>Platform Circular Flevoland</b>	Flevoland, NL	Enterprises, SME, start-ups, knowledge institutes	Soft instrument	Systemic
<b>Additive Manufacturing (AM) Pilot Plant</b>	Greater Manchester, UK	Enterprises, SME, start-ups	Soft instruments	Technology push
<b>North West of England CE Hub</b>	NW-England, UK	SME	Soft instruments	Systemic
<b>Plastic to Hydrogen Facility</b>	Ellesmere Port, UK	Enterprises	Financial instrument	Technology Push

#### 4. Wallonia, Belgium

On September 25<sup>th</sup> 2015, General Assembly of the United Nations published a resolution<sup>19</sup> concerning the sustainable development on the horizon 2030. Seventeen European objectives<sup>20</sup> resulted from that and Belgium integrated them. Those objectives cover varied themes, such as Health, Poverty, Education, Water or Climate. The Walloon Plan of Waste-Resources<sup>21</sup> (shorten to PWD-R in French), which is re-examined every 6 years, is involved in almost the whole set of European objectives, taking actions mainly in SDG12<sup>22</sup>, "Ensure sustainable consumption and production patterns", with 116 measures out of the 157 planned ones.

In concrete terms, actions led by Wallonia are organised through five approaches.

1. First, a strong database constitution is paramount, reflecting the reality as far as waste management is concerned. That database will lead to a better industrial waste traceability, an optimisation of the tax system, in order to meet environmental requirements, an information centralization relating to waste irregularities, and so on. All that with an administrative simplification. Those measures represent the **context**.
2. The second approach is **prevention**. This is, on the one hand, a work of support and (financial) encouragement for companies in their efforts to fight against food waste, limit the distribution of unwanted press/advertising or develop composting, reuse/repair of equipment, etc. On the other hand, this will be the promotion of information and awareness of eco-design, in companies or schools. Control and sanction tools will also be put in place (discouragement of infringements, fight against litter).
3. Next, there is proper waste, with, on the one hand, the management of **household waste**. The region will seek to improve the possibilities for recycling household waste (R&D), promote innovation in selective collection (for example: generalizing P+MC and ensuring the separation of the organic fraction from raw household waste in order to add value), optimize the operation of recycle parks, minimize the risks associated with the waste collection business, etc.
4. On the other hand, there remains the management of **industrial waste** with, among other things, the establishment of a circular strategy committee, the creation of new sorting obligations at source, the promotion of recycling of biodegradable waste (recovery into animal feed or green chemistry), maximizing the heat gain from energy recovery units, or the development of infrastructures in industrial symbiosis.
5. Finally, the last spearhead of Wallonia is **public cleanliness**. This will involve adapting the regulatory framework with a view to promoting the improvement of public cleanliness, implementing the ban on the provision of single-use plastic bags, integrating the management

---

<sup>19</sup> French version of General Assembly of the United Nations' resolution. "Transformer notre monde : le Programme de développement durable à l'horizon 2030". Online:

[https://www.un.org/ga/search/view\\_doc.asp?symbol=A/RES/70/1&Lang=F](https://www.un.org/ga/search/view_doc.asp?symbol=A/RES/70/1&Lang=F)

<sup>20</sup> From "Sustainable development in the European Union". Monitoring Report on Progress Towards the SDGs in an EU context. Online : <https://ec.europa.eu/eurostat/documents/3217494/8461633/KS-04-17-780-EN-N.pdf/f7694981-6190-46fb-99d6-d092ce04083f>

<sup>21</sup> In French "Plan Wallon des Déchets-Ressources (PWD-R). The third edition, updated on March 22<sup>th</sup> 2018, is in free download here: <http://economiecirculaire.wallonie.be/economie-circulaire-en-wallonie>

<sup>22</sup> SDG's for Sustainable Development Goals

of public cleanliness in town planning schemes or even educate and raise awareness among citizens from an early age. Support for municipalities in identifying those responsible for illegal dumping or littering is also planned.

In order to achieve all these objectives, Wallonia surrounds itself with numerous stakeholders, with whom it is implementing several initiatives. Amongst those are:

- Public Service of Wallonia (SPW) itself operates a web platform ([economiecirculaire.wallonie.be](http://economiecirculaire.wallonie.be)) dedicated to circular economy, with resources for enterprises and organises some specific initiatives such as the “Green Deal Circular Purchase” where companies commit themselves to include more circularity in their purchase progress and are introduced to potential facilitators that may help them achieving their goals. Another Walloon initiative are the “Circular Economy Paychecks” through which SMEs can have 75% financed feasibility studies and technical consultancy for CE projects (max. 45 k€ / 3 years).
- Inter-municipalities, like **IDEA**<sup>23</sup>, acronym for “*Intercommunale de Développement Economique et d’Aménagement du coeur du Hainaut*”. IDEA is a public society, created by the municipalities themselves to rule municipal interest matters, as water treatment and distribution, sustainable energy technologies (like geothermal water) or town planning. It has also an advisor role to SME’s. Its field lies in Province of Hainaut, embracing mainly Mons and the neighbouring municipalities. Similar organisms exist in the rest of Wallonia, such as **Ipalle**<sup>24</sup> (water, energy and waste), for Wallonia-Picardy or **Idelux**<sup>25</sup> (water and waste), for Province of Luxembourg. Synergies exist between inter-municipalities that may seem to have geographical and/or functional overlaps but in fact have slightly different competences and goals.
- Competitiveness clusters that aim to develop the industries, in an innovation process, through several approaches, including research and development projects. Below are some of them:
  - **Plastiwin**<sup>26</sup>, which is the Walloon Cluster of Plastics, with a network of companies that have specialized in polymers, biopolymers, elastomers, composite materials and synthetic textiles whose main applications are packaging, automotive, railways, aeronautics, construction, medical, electrical engineering and environment.
  - **GreenWin**<sup>27</sup>, which is the most recent competitiveness cluster and is dedicated to green chemistry and white biotechnology. GreenWin has given itself the mission of "contributing to a sustainable, innovative and eco-responsible Wallonia".
  - **Mecattech**<sup>28</sup>, which is specialized in mechanical engineering. From 2007 to 2018, with its 23 calls for project, MecaTech gathered more than 140 SME's, 78 university laboratories and 18 research centres.
- Platforms, such as **PEPIT**<sup>29</sup>, for “**P**olymers **E**cocircularity **P**latform for an **I**ndustrial **T**ransition”, which is a means of centralizing calls for project about circular economy. It was funded by the

---

<sup>23</sup> Website: <https://www.idea.be/fr/accueil.html>

<sup>24</sup> Website: <https://www.ipalle.be/>

<sup>25</sup> Website: <https://www.idelux.be/fr/accueil.html?IDC=2497>

<sup>26</sup> Website: <http://clusters.wallonie.be/plastiwin-fr/>

<sup>27</sup> Website: <https://www.greenwin.be/fr/>

<sup>28</sup> Website: <https://www.polemecattech.be/fr/>

<sup>29</sup> Website: <https://www.greenwin.be/fr/page/pepit>

above-mentioned three clusters, with the support of many other stakeholders, such as R&D centers Celabor, Centexbel, Certech, Materia Nova or Sirris.

Below, three approaches, concerning sustainable development and the circular economy, have been selected and presented, either for their innovative or current character, or on the contrary for their durability. The clusters or stakeholders mentioned above are most often involved in one or other of these initiatives.

#### **4.1 Best Practice 1 – Challenge “Plastics Go Green and Circular”**

Like the GreenDeal Circular Purchase<sup>30</sup>, the "Plastics Go Green and Circular" challenge<sup>31</sup> aims to develop relevant and ambitious projects on the theme of the circular economy and sustainable development. Where, in the GreenDeal, volunteers will be able to position themselves as buyers ("project managers") or facilitators ("project partners"), the PGGC challenge is organised differently.

This opportunity is aimed mainly at SMEs and start-ups and consists, as a first step, in identifying (by August 2020) 10 major challenges related to the circular economy with regards to plastics. Once these have been selected, a call for projects is launched and 10 projects, related to the challenges identified, will be chosen (October 2020). Finally, personalised support and a subsidy of €15,000 per project will be awarded.

The main thematic lines of the PGGC Challenge are the optimisation of the use of plastic resources, their substitutions by alternatives (bioplastics), the extension of the life of the products (by repair, reuse or reconditioning) and recycling. The various strategies targeted lie in improving technology or design, in order to facilitate the recycling or reuse of products, the improvement of separate collection, intelligent return logistics in order to improve traceability, or even development of new business models.

This approach is initiated by the Public Service of Wallonia and financed by the European Union. It is supported by various partners, in particular GreenWin, PlastiWin, MecaTech and PEPIT as above-mentioned.

#### **4.2 Best Practice 2 – Yara, Tertre**

The Tertre industrial zone<sup>32</sup> (Saint-Ghislain, Hainaut, Belgium) has the particularity of accommodating companies that operate in synergy. The site is in fact an "industrial ecology" trial coordinated by IDEA. The underlying purpose was to re-design the industrial park as an ecosystem.

---

<sup>30</sup> More information online: <http://economiecirculaire.wallonie.be/green-deal>

<sup>31</sup> From the Public Service of Wallonia (SPW in French) website:  
<http://economiecirculaire.wallonie.be/challenge-plastics-go-green-and-circular>

<sup>32</sup> More information online: <http://economiecirculaire.wallonie.be/symbioses-industrielles-et-partage-des-ressources>

Historically, this industrial zone was created about a century ago thanks to the extraction of coal in the region and its actors were already collaborating, by exchanging different resources (coking gas to produce organic molecules, metals, etc.). It has gradually evolved into a Seveso site, since it notably hosts 8 chemical companies, representing an area occupied by approximately 110 ha and 620 jobs. These have certain logistical advantages that facilitate their trade, since they are served by road, rail and water.

As part of the experiment conducted by IDEA, 25 scenarios for valuing materials and by-products were identified. Likewise, the pooling of flows, such as the circulation of water or electricity has been favoured with a single line. But among these industrialists, it was Yara, a producer of fertilizers and nitrogen products, which was a key company. With its activity, it recovers its by-products directly and on site, such as carbon dioxide (AirProduct), ammonia (Prince) and concentrated nitric acid (Maxam).

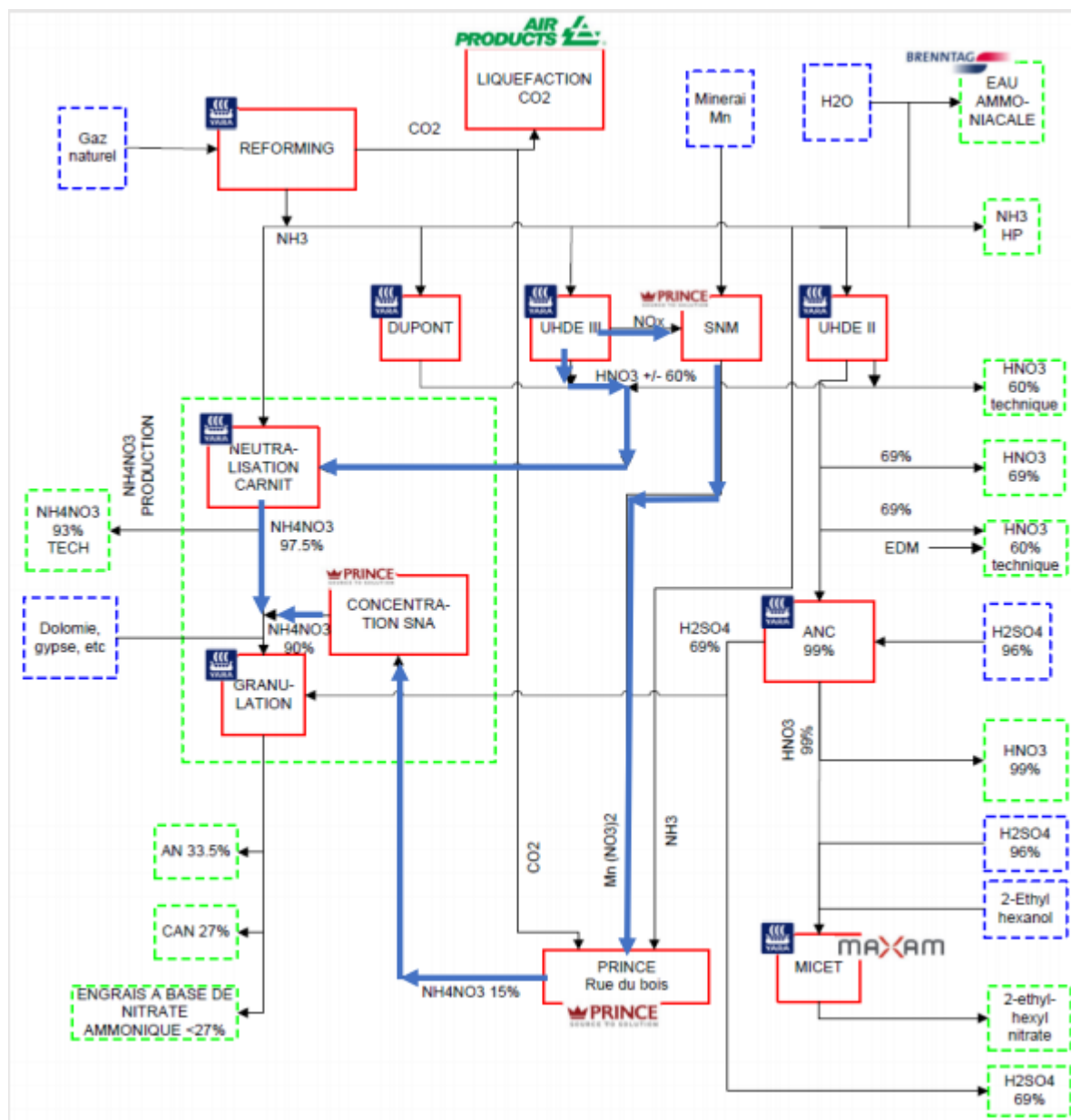

**Figure 1:** Collaboration scheme between the different companies located in Tertre.<sup>33</sup>

### 4.3 Best Practice 3 – Circular Economy Facilitator

In addition to the support and advice to companies or awareness in schools offered by the inter-municipalities (IDEA, Ipalle, Idelux, etc.), the Belgian state, via the public organism Forem, recently opened a training course for a “circular economy facilitator<sup>34</sup>”, which could also find a role in the above-mentioned inter-municipalities. At the end of this training, the facilitators are able to:

1. Inform, raise awareness and train all members of the organization (company or territory) in the challenges of the circular economy.
2. Support decision-makers in companies and regions in their strategy (new business model) taking into account the challenges of the circular economy.
3. Identify and analyse the local / regional / national / cross-border ecosystem made up of the organization's stakeholders (workers, suppliers, customers, residents, neighbouring companies, shareholders, public authorities, potential partners, etc.).
4. Analyse the institutional, regulatory, technological and geostrategic context in which the organization operates and carry out continuous monitoring (benchmarking, success stories, etc.).
5. Map and analyse the supply and demand of resources (tangible and intangible) within the organization and its ecosystem.
6. Identify and develop opportunities for internal and external action alone or in partnership in a systemic logic.
7. Initiate and coordinate the management of projects resulting from the defined action plan (including results measurement, evaluation and reporting).
8. Support departments in the change required for the implementation of projects related to the circular economy.
9. Create and maintain an approach of cooperation and co-creation internally and externally (network operation and development of collective intelligence).
10. Support communication to the outside world and the dissemination of good practices.

Whoever embarks on this training must have a scientific, economic and managerial background. In addition, he must present an open-mindedness and a strategic vision, in addition to being a good teacher, to show empathy with decision-makers and heads of departments, as well as a good capacity for adaptation, while being mindful of the collective interest. The first promotion of facilitators entered the job market end of summer 2020, and a new promotion of trainees is starting the program in September 2020.

---

<sup>33</sup> <sup>33</sup> Essais d'écologie industrielle coordonnés par IDEA, Cycle de webinaires en économie circulaire 9 juillet 2020, page 9/27. Retrieved from: <http://economiecirculaire.wallonie.be/sites/default/files/2020-07/Webinaire%20Ecologie%20industrielle%2009.07.2020.pdf>

<sup>34</sup> Complete description of the training here: [https://www.leforem.be/MungoBlobs/1391427892678/20160112\\_Rapport\\_A2P\\_LeFacilitateurEnEconomieCirculaire.pdf](https://www.leforem.be/MungoBlobs/1391427892678/20160112_Rapport_A2P_LeFacilitateurEnEconomieCirculaire.pdf)



## 5. Germany with a focus on Rhineland Palatinate and Northrhine Westfalia

On a national level, Germany has an extensive regulatory framework concerning waste management of both, public and private organisations, and the production and marketing of goods. At the centre of these multiple directives and regulations concerning waste is the *Kreislaufwirtschaftsgesetz*, which aims to promote circular economy under the premise of resource conservation and the protection of the human and environmental health. It transfers the waste hierarchy as defined by the European Waste Framework Directive into national law and sets the following goals for the German circular economy accordingly:

- The preparation for reuse and recycling of municipal solid waste should account for at least 65 mass-% in 2020. This is more ambitious than the EU regulation, which aims 55% of municipal waste to be recycled and prepared for reuse by 2025, 60% by 2030 and 65% by 2035.<sup>35</sup>
- Concerning non-hazardous construction and demolition waste, the target value for reuse, recycling and other material usage is set to 70 mass-% by 2020.

The German packaging law, *Verpackungsgesetz*, adds specific targets for the packaging sector and defines obligations for separate collection of packaging waste. One specific aim of the law is to increase the usage of reusable packaging for beverages and drinks to 70%, and introduce a mandatory deposit-return system (*Pfand- und Rücknahmepflicht*) for disposable (single use) beverage packaging made of i.a. plastic and composite materials. Some packaging for specific drinks or purposes, such as fruit juices, milk or drink pouches made from PE foils, are excluded from this regulation. Next to these systemic regulations for (i.a. plastic) packaging for the beverage sector, the law generally sets a recovery target of 65 mass-% for packaging waste and a recycling target of 55 mass-% of the total packaging waste annually. Of these total packaging waste targets, plastic packaging waste should account for a minimum of 22.5 mass-%, whereas only materials, that can be reprocessed as plastic through recycling, are considered.<sup>36</sup> Furthermore, businesses are obliged to increase source separation and recycling of different commercial and industrial waste flows at the company level according to the *Gewerbeabfallverordnung*. The obligation of source separation of i.a. plastic waste for companies ceases to apply, when a minimum of 90 mass-% of the company's total waste occurrence is collected separately for recycling.<sup>37</sup>

Following the Single-Use Plastics (SUP) directive of the EU, Germany is developing a national legislation to ban certain SUP products, such as cotton buds, straws, plates, cutlery, beverage stirrers and balloon sticks. Furthermore, food containers made from polystyrene and beverage containers and beverage cups for take away will be banned whether they are made from fossil or biological polymers and whether they are biodegradable or not. Implementing this legislation, the German government aims to reduce the 346,000 tons of SUP waste in 2017 from beverage

---

<sup>35</sup> Compare KrWG § 14 and Directive (EU) 2018/851 of the European Parliament and of the Council of 30 May 2018 amending Directive 2008/98/EC on waste (OJ L 150, 14.06.2018, p. 109-140).

<sup>36</sup> Compare VerpackG § 1 and § 31

<sup>37</sup> GewAbfV § 4



packaging and to go packaging, which are likely to contribute to littering and environmental pollution.<sup>38</sup>

Next to the national regulatory framework, that sets the baseline for circular economy in Germany, the 16 federal states complement with regional specific regulations and objectives. On a more regional level, some public authorities and municipalities, as well as companies comply to internal, specific targets and regulations concerning the circular economy of plastics. Subject to this report are the regulations of Rhineland-Palatinate (RLP) and North-Rhine Westphalia (NRW). These two federal states are covered by the TRANSFORM-CE partners and are significant contributors to the circular economy of the NWE programme area bordering the Netherlands, Belgium, Luxemburg and France.

Both federal states are influenced by European and national legislation and translate and adapt the superordinate regulations in the field of circular economy to their specific context via regional legislation, such as the *Landesabfallgesetz* in NRW and the *Landeskreislaufwirtschaftsgesetz* RLP. Both define specific targets furthermore in their waste management strategies, the so called *Abfallwirtschaftsplan*. According to the legislation of both federal states, municipalities are obliged to define their own communal waste management concepts, where they define targets and actions to meet the national and federal goals of waste treatment, circular economy and recycling rates.

In NRW and RLP, the main principle of circular economy is the implementation of a regional autarky for waste management, which consists of the two elements of creating infrastructure and capacities for waste treatment with a focus on recycling, and implementing the concept of proximity for waste treatment to reduce transport and loss of regional resources. The recycling goal of NRW and of RLP is equivalent to the one of Germany, whereas both federal states are on a good track to meet their input-related recycling goal of 65 mass-% of the total municipal solid waste (MSW) in 2020. Since the past 10 years NRW has a positive trend of recycling rates and the recycling rate of MSW reached 56% in 2017. RLP had a recycling rate of 64.5% of its total household waste in 2018. Additionally, NRW sets the target of recycling a minimum of 50 mass-% of valuable household wastes (paper, glass, plastics and metals). This target has been exceeded, as in 2017 76% of valuable waste from households have been treated in an MBT with the aim to be prepared and conditioned for recycling.<sup>39</sup> In RLP, the national regulations on circular economy are expanded by emphasizing not only on recycling but prioritising the best possible valorisation option per material flow according to its specific characteristics and valorisation potentials. Additionally, municipalities are explicitly encouraged to change their fee system in order to create incentives for waste reduction and better source separation.<sup>40</sup>

---

<sup>38</sup> The Federal Government, 2020: "Einweg-Plastik wird verboten" <https://www.bundesregierung.de/breg-de/themen/nachhaltigkeitspolitik/einwegplastik-wird-verbotten-1763390>

<sup>39</sup> Abfallwirtschaftsplan Nordrhein-Westfalen, 2017, and Abfallbilanz Nordrhein-Westfalen für Siedlungsabfälle 2017

<sup>40</sup> Abfallwirtschaftsplan Rheinland-Pfalz, 2013, and Landesabfallbilanz Rheinland-Pfalz 2018

Beyond the administrative strategies and targets for circular economy, there exist voluntary initiatives, cooperation and strategies on the company and municipality level to increase circular economy specifically in the plastic sector. For example, some stakeholders of the German plastics economy are part of the global “Alliance to end plastic waste” where they commit to cooperate with different stakeholders to develop solutions to plastic waste challenges.<sup>41</sup> A regional example for a public-private-partnership is the *Hamburgs Wertstoff Innovative*, where different public, private and scientific partners in Hamburg cooperate to increase recycling and establish a local circular economy. Together, they developed a local detergent packaged in a bottle made of 100% recycled HDPE from post-consumer plastic waste of the city of Hamburg, which is sold exclusively in Hamburg.<sup>42</sup>

Exemplary for the different instruments and regulations existing in Germany, the following three best practices will be analysed in detail:

- Production-integrated environmental protection;
- Green public procurement of recycled plastics;
- Voluntary return system of plastic profile manufacturers.

### 5.1 Best Practice 1 – Production-integrated environmental protection (PIUS)

The *Production-integrated environmental protection (PIUS)* portal is a Germany-wide database on the subject of resource efficiency in companies.<sup>43</sup> In the German federal states of North Rhine-Westphalia, Rhineland-Palatinate, Hesse and Baden-Württemberg, the PIUS concept provides funding for especially small and medium-sized enterprises (SMEs) for example to obtain consulting services on the topic of production-integrated resource efficiency. The term PIUS refers to the sustainable use of energy and resources within production operations. The aim of production-integrated environmental protection is to reduce the environmental impact of a company (or a part of the company). This is achieved by avoiding or reducing emissions and increasing resource efficiency and circular economy - both in the area of raw material use and in the area of (re)use and recycling. This also involves the avoidance or enhanced recycling of wastewater and waste. For the companies, the optimized environmental protection of their production results in economic advantages, such as cost reductions, increased productivity, and the minimization of emissions. The following process-optimising possibilities can be applied or promoted through:

- Use and establishment of material cycles
- Reduction or simplification of procedural steps
- New plant and process concepts

The choice of the method to be used always depends on a case-by-case decision as well as on the general conditions.

---

<sup>41</sup> For more information, please check: <https://endplasticwaste.org/>

<sup>42</sup> For more information, please check: <https://hamburgs-wertstoff-innovative.de/>

<sup>43</sup> PIUS Info-Portal, available at: <https://www.pius-info.de/>

Since 2007, companies in Rhineland-Palatinate have been supported by the Rhineland-Palatinate Ministry for the Environment, Energy, Food and Forestry in carrying out analyses on production-integrated environmental protection. The project *EffCheck- Resource Efficiency in Rhineland-Palatinate* offers companies the opportunity to have cost saving possibilities within their production checked by a consulting company. The savings potential in the areas of energy, water, materials, emissions and waste identified by EffCheck can then be used by the companies as a basis for implementing operational actions.

In Hessen and North Rhine-Westphalia, there exist funding schemes similar to the one in Rhineland-Palatinate. *PIUS-Beratung* and *PIUS-Invest* are initiatives of the Hessian Ministry of Economics, co-financed by the European Regional Development Fund. *PIUS-Beratung* is a central component of PIUS support in Hesse, with financial support being provided for the provision of advice to Hessian SMEs in the production, trade and service sectors. *PIUS-Invest* supports innovative investment projects that improve resource efficiency and abate CO<sub>2</sub>e emissions, as well as exceeding the minimum legal requirements. The *EFRE NRW - Förderwettbewerb EnergieUmweltwirtschaft.NRW* lays its focus on supporting projects that develop climate- and environmentally friendly innovations and solutions.

## 5.2 Best Practice 2 – Green public procurement of recycled plastics

The German Environment Agency developed and published a guideline to support green public procurement of recycled plastics.<sup>44</sup> It provides concrete examples of how public institutions can and should contribute to strengthening the circular economy of plastics by stimulating the demand for products made from recycled plastic. These products should be made from more than 90 mass-% of plastics, of which over 80% should be recycled post-consumer plastics and include typical items of the public procurement, such as:

- Office supplies (e.g. letter trays, drawer boxes, writing utensils),
- Bins and containers (e.g. for waste collection, as flower pots, for office organisation),
- Outdoor furniture (e.g. benches, tables, chairs),
- Palisades, fences and lawn rails,
- Playground equipment,
- Composting facilities and collection bins,
- Products made from plastic foil (e.g. bags, cover tarpaulins, covering foil).

Public institutions have several options to include environmental aspects in the tendering process. Priority is given to the desired recycle content of the product and the origin of the secondary plastic, e.g. from post-consumer wastes. Furthermore, public institutions can specify the amount or exclude polymer types and substances, that are potentially hazardous and have adverse effects on the recyclability. Examples for these unwanted substances (whether included in the recycle or added in the compounding process) and their acceptable limits are given for phthalates, halogens and heavy metals. As a third environmental criteria, the guideline recommends to pay

---

<sup>44</sup> German Environment Agency (Umweltbundesamt), 2020: Leitfaden zur umweltfreundlichen öffentlichen Beschaffung: Produkte aus Recyclingkunststoffen

special attention to the risk and safety statements to assess and label hazardous and dangerous chemicals and compounds as defined by European legislation.<sup>45</sup>

As a last step for green public procurement, verification management is essential, to control whether the desired environmental aspects are respected and fulfilled. This can be achieved by paying attention to quality labels, such as *Blauer Engel*, or specific certificates from a conformity assessment body, such as *Technischer Überwachungsverein (TÜV)*.

As one of the adopters of this guideline, the City of Münster in the German federal state of North-Rhine Westphalia pays special attention to request recycled plastic in its public procurement of plastic materials. This is the case currently for all kinds of office supply, such as boxes, pens, stamps, tapes and sharpeners.

### 5.3 Best Practice 3 – Voluntary return system of plastic profile manufacturers

An example for a soft instrument initiated by the private sector to increase circular economy of plastics is the Rewindo GmbH, a voluntary return system for old plastic profiles.<sup>46</sup> The Rewindo GmbH as a commercial association with its headquarters in Bonn is an alliance of 11 leading plastic profile manufacturers in Germany with the common goal of increasing the recycling of PVC profiles, as used in windows, shutters and doors. As such, Rewindo is part of the European initiative VinylPlus, which is a voluntary commitment of the European PVC sector for sustainable development and circular economy. The main goals of VinylPlus are the reduction of emissions from PVC production, the substitution of lead as a stabiliser in PVC production, and the reuse and recycling of PVC wastes.<sup>47</sup> Rewindo contributes to the latter by producing 33,300 t of PVC recyclate in 2018 for usage in new PVC profiles products. The circular economy model of Rewindo is visible in figure 2.

---

<sup>45</sup> Commission Directive 2001/59/EC of 6 August 2001 adapting to technical progress for the 28th time Council Directive 67/548/EEC on the approximation of the laws, regulations and administrative provisions relating to the classification, packaging and labelling of dangerous substances

<sup>46</sup> For more information, please check: <https://rewindo.de/>

<sup>47</sup> For more information, please check: <https://vinylplus.eu/>.

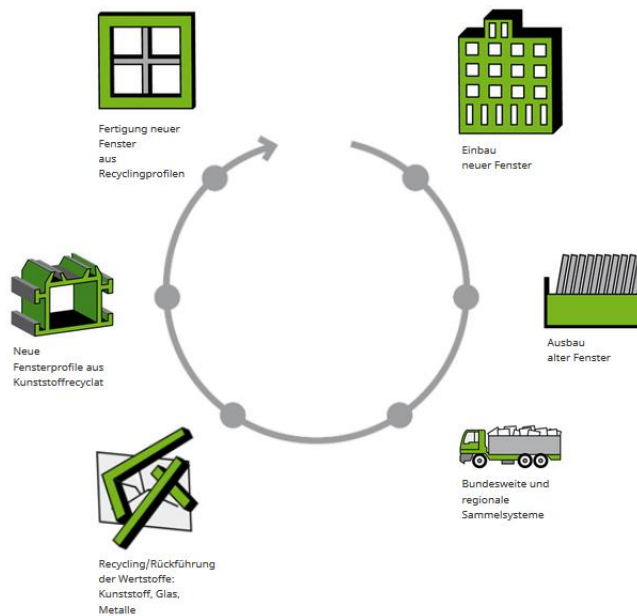

**Figure 2:** Circular economy of PVC profiles as performed by Rewindo

Rewindo is responsible for the collection of the waste windows, doors and shutters from the waste producer, thus the customer of the plastic profile manufacturers. Most of the time, the dismantling of old windows takes place as part of a replacement process. For waste treatment and recycling, Rewindo subcontracts recyclers in order to separate the PVC from glass, metals and other materials as well as compounding to produce a regranulate. This regranulate is provided to the plastic profile manufacturers to be used in the production of new windows, doors and shutters. With the state-of-the-art technology, the PVC can be recycled up to seven times for the same purpose and contribute to lowering emissions from primary material production as well as closing material loops as envisioned by circular economy. From an economic point of view, the plastic profile manufacturers do not only profit from receiving a recycled polymer tailored to their production needs and beneficial to their marketing strategy, but they also increase their attractiveness and portfolio to their customers by offering an end-of-life service. At the same time, plastic profile manufacturers can sell new products, as in many cases the windows, doors or shutters are being replaced with new ones.

## 6. Central Netherlands

On a national level, the Netherlands developed a government-wide circular economy program called *Nederland circulair in 2050*, focussing on the development to achieve a circular economy within the Netherlands before 2050.<sup>48</sup> An intermediate objective has been set for 50% less use of primary raw materials (minerals, fossils and metals) in 2030. For plastics the goal is to use 100% recycled or biobased plastics by 2050. As part of this program, five different transition agendas have been developed by the national government (Rijksoverheid), including the *transition agenda plastics*.<sup>49</sup> The *CE implementation plan* (Uitvoeringsprogramma circulaire economie)<sup>50</sup> translates the goals set in the agendas into concrete actions and projects for 2019-2023. This includes the development of *Plastic Pact NL*, signed by over 70 organisations.<sup>51</sup> Within this pact, organisations have a shared ambition to reduce plastic waste and reuse materials. Goals set for 2025 are to use 20% less plastic, make all packaging recyclable, recycle over 70% of plastic packaging and use an average of 35% post-consumer recycled materials per company. Agreements made in this pact are in line with comparable agreement frameworks, such as the Plastic Pact UK, the French Plastic Pact and the EU single use plastics guidelines.

Additionally, the *CE implementation plan* has set concrete targets such as reaching a minimum of 10% chemical recycling by 2030, improving the quality of sorted plastic waste streams to 95% mono streams in 2025 (compared to 55% in 2017), and determining the required purity of the recycle and applying standards that are scaled up internationally (ISO) in inventory programs.<sup>52</sup> In line with the EU-goals to make plastic products easily recyclable, a certain tariff differentiation (*tariefdifferentiatie*) has been introduced in the Netherlands, providing businesses with a discount on good recyclable packaging (within Dutch recycling systems).<sup>53</sup>

In addition to a national overview we take a regional approach, because a substantial part of the responsibility to develop a CE has been put at the level of provinces and municipalities. For the Netherlands, focus is placed on the central region. This includes the two provinces that lack a foreign border or a connection to open sea: Flevoland and Utrecht, and their major cities Almere

---

<sup>48</sup> MinIM & MinEZ. (2016). *Nederland Circulair in 2050*. Retrieved from:

<https://www.rijksoverheid.nl/onderwerpen/circulaire-economie/documenten/rapporten/2016/09/14/bijlage-1-nederland-circulair-in-2050>

<sup>49</sup> Transitie-agenda Kunststoffen. (2018). *Transitie-agenda Circulaire Economie – Kunststoffen*. Retrieved from:

<https://www.rijksoverheid.nl/onderwerpen/circulaire-economie/documenten/rapporten/2018/01/15/bijlage-3-transitieagenda-kunststoffen>

<sup>50</sup> MinIM & MinEZ, (2019). *Uitvoeringsprogramma Circulaire Economie 2019-2023*. Retrieved from:

<https://www.rijksoverheid.nl/onderwerpen/circulaire-economie/documenten/rapporten/2019/02/08/uitvoeringsprogramma-2019-2023>

<sup>51</sup> MiniW (2019). *Plastic Pact NL*. Retrieved from: <https://www.rijksoverheid.nl/onderwerpen/circulaire-economie/documenten/kamerstukken/2019/02/20/plastic-pact-nl>

<sup>52</sup> MinIM & MinEZ, (2019). *Uitvoeringsprogramma Circulaire Economie 2019-2023*. Retrieved from:

<https://www.rijksoverheid.nl/onderwerpen/circulaire-economie/documenten/rapporten/2019/02/08/uitvoeringsprogramma-2019-2023>.

<sup>53</sup> Afvalfonds Verpakkingen, 2019. Tariefdifferentiatie kunststof. Retrieved from:

<https://afvalfondsverpakkingen.nl/verpakkingen/tariefdifferentiatie-kunststof>



and the City of Utrecht. The 1,7 million inhabitants of Flevoland and Utrecht live mainly in these two major cities.<sup>54</sup>

In general we find provinces to be influenced by national and European policy objectives. Both Flevoland and Utrecht stress the (business) opportunities which a shift to a CE could bring, and their responsibility to contribute to global challenges.<sup>55</sup> Flevoland aims to be a supplier of circular resources by 2030: 1) use of bio based resources and 2) reuse of materials. Utrecht proposes to be a circular top region by 2050. The region sees three important facets: 1) new initiatives in circular business models, 2) transitioning traditional business models to circular ones, and 3) ending linear practices.

In addition to general attention and long term objectives for 2030 and 2050, both provinces are working on concrete plans. Noteworthy is the ambition on circular purchasing and procurement, that is part of a common agenda by regional and local governmental bodies. For instance, the province of Flevoland and all its municipalities have signed to aim for 10% circular purchasing by 2022 and subsequently build this up to 50% by 2025.<sup>56</sup> Municipalities, provinces and water boards set up an investment agenda in which they pledge to yearly invest and procure for € 28 billion in durable, energy and climate neutral and circular initiatives.<sup>57</sup> On a province level clear objectives are still in progress.<sup>58</sup>

The municipalities of Almere and Utrecht are also working on implementing CE and have set the following objectives:

- City of Utrecht: The City of Utrecht has the ambition to become waste free and to be fully circular in 2050. The municipality of Utrecht has accomplished 10% circular purchasing in 2020 and goals are set to reach 33% by 2023. For the longer term an action plan is made (*Utrecht circulair 2020-2023*),<sup>59</sup> but without specific objectives.
- Almere: The city of Almere has the ambition to become a waste free city and has set goals for the future to recycle all waste and reach 0 kg of residual waste per person, although no specific timeframe has been proposed. They have already accomplished to bring back residual waste

---

<sup>54</sup> The other major cities are Lelystad and Amersfoort.

<sup>55</sup> Provincie Flevoland. (s.d.). *Omgevingsvisie Flevoland Straks*. Provincie Utrecht. (2018). *De Nieuwe Utrechtse Stijl*. Utrecht: Provincie Utrecht.

<sup>56</sup> Provincie Flevoland. (2019). *Samen maken we Flevoland – Uitvoeringsagenda deel 1*. Lelystad: Provincie Flevoland.

<sup>57</sup> IPO, Unie van Waterschappen, VNG. (2017). *Naar een duurzaam Nederland*. Den Haag: IPO, Unie van Waterschappen, VNG

<sup>58</sup> Ask can for example be seen in the policy document from Provincie Flevoland. (2019). *Samen maken we Flevoland – Uitvoeringsagenda deel 1*. Lelystad: Provincie Flevoland; and an analysis by USI. (2020). *Circulaire doelenboom als sturingsinstrument*. Utrecht Sustainability Institute, 11 May 2020.

<sup>59</sup> Gemeente Utrecht. (2020). *Utrecht presenteert actieprogramma Utrecht Circulair*. Retrieved from: <https://www.utrecht.nl/nieuws/nieuwsbericht-gemeente-utrecht/utrecht-presenteert-actieprogramma-utrecht-circulair/>



from 180 to 50 kg per person.<sup>60</sup> The municipality of Almere has signed to aim for 10% circular purchasing by 2022 and subsequently build this up to 50% by 2025.

Circularity and supporting the development of a CE is a major policy theme in the region, on both province and municipality level. Especially with procurement and purchasing the regional governments can have an important impact, and this is recognised. Still it is not clear what circularity entails and what specific policy programmes could be developed. At the same time several interesting examples are taking place. Three best practices that relate to the recycling of plastics in the central Netherlands region have been selected and will be further elaborated on below.

### 6.1 Best Practice 1 – Circular plastic factory<sup>61</sup>

Almere wants to realise a local CE and the Province of Flevoland wants to become the raw material supplier for CE. In line with Almere's ambition to reach zero residual waste per person in the future (VANG HHA, s.d.), the municipality wants to recover, recycle and reuse mix plastics locally. From the collected plastics of household packaging waste, a 'low-grade' mix and foil fraction (50%) remains after sorting, which has little to no value or demand from plastic producers. This results in a surplus of mix plastic waste and insufficient application possibilities. Since there is no other company in the Netherlands using mixed plastics, a circular plastic factory (Circulaire Plasticfabriek) is set up (which is also part of the TRANSFORM-CE project).

The circular plastic factory is an initiative of the municipality of Almere in collaboration with Save Plastics, Province of Flevoland, Metropole Region Amsterdam (MRA) and Floriade. With this factory, about 2.000 ton of mixed plastics will be recycled to products that municipalities, water boards and provinces in the MRA region can use in products for public spaces. This offers organisations the possibility to increase circular purchasing and achieve objectives such as 50% circular purchasing by 2025 set by the province of Flevoland (Omgevingsvisie Flevoland, 2019).

However, finding partners to create a market for such products still seems to be one of the biggest challenges. Organisations are very enthusiastic at the beginning but are dropping out when plans get more detailed. Moreover, larger stakeholders seem to be willing to work on economies of a larger scale rather than regional, local initiatives.

### 6.2 Best Practice 2 – Circular City Bin<sup>62</sup>

When it comes to supporting sustainability, the city of Utrecht tries to influence companies by pursuing Social Responsible Procurement. Currently, the City of Utrecht focusses mainly on tendering. This has led to several interesting examples, including circular tenders. Regarding plastics the recently procured City Bin is a good example of what the municipality is trying to

---

<sup>60</sup> VANG-HHA. (s.d.). *Almere did it: van 180 naar 50 kilo restafval per inwoner per jaar*. Retrieved from: <https://www.vang-hha.nl/nieuws-achtergronden/2018/almere-did-it-180-50/>

<sup>61</sup> With thanks to Bram Peters (Save Plastics), Johan Luijks (Gemeente Almere) and Paul Mul (gemeente Almere, RHDHV).

<sup>62</sup> With thanks to Gerhard Schoonvelde (Gemeente Utrecht).

accomplish with circular procurement. Last year the municipality put out a new tender for the city bins in use by consumers. Next to traditional criteria such as prize and quality, the tender specified the following circularity criteria:

- The body and lid of the bin are made of coloured HDPE and may consist of maximum 50% virgin material.
- The bins are provided with a production date so the batch can be traced. Tracing will allow the contractor to demonstrate the composition of the granulate.
- The bin is reusable. At end-of-life all parts of the bin are either reusable or recyclable.
- The contractor guarantees that bins will be reused. If reuse is not possible it is guaranteed that the bin will be collected by the municipality and will be used as input for the production of new bins.

The document stated clear circular requirement criteria, though, some non-circular criteria might be conflicting to the circular ones. When looking at the requirements document, possible conflicts may arise with a few specifications. The top of the rolling bins must be available in different colours, where especially blue, yellow and orange are difficult to realise with recycled feedstock. The requirements document allows for a mix of recycled (at least 50 percent) and virgin feedstock, which in most cases leads to degradation of virgin feedstock. Moreover, the circular requirements do not apply to other parts than the body, such as the wheels, chips and handle.

Four companies made an offer to the city of Utrecht. The municipality used a weighed approach with the following criteria to select the best fit: price as low as possible (30%), circularity score (30%), validation of granulate composition (15%) and action plan testability composition of granulate (25%).

Instead of using virgin material, these kinds of procurement procedures have stimulated businesses to apply recycled material. Specific goals for percentage of recycled feedstock by municipalities are said to stimulate companies to produce products from (partly) recycled material. From that perspective, the requirements for reuse and refurbishment for the circular city bins could lead to companies applying higher order circular strategies than recycling. Though, the municipalities' functional requirements are ambiguous: demanding reuse *or* recycling. Meaning that old city bins could both be refurbished, or shredded and reproduced through recycling. Nevertheless, both options are a substantial improvement regarding material use.

### 6.3 Best Practice 3 – Platform Circular Flevoland

The province Flevoland sees an opportunity in the changeover to a circular economy. The region aims to position itself by 2030 as the resource supplier for the circular economy. To establish this role, the province is working to connect relevant stakeholders. This is being done in the Platform Circular Flevoland.<sup>63</sup> This platform organises a bi-annual meeting for matchmaking, knowledge transfer about new and established circular supply chains.

---

<sup>63</sup> For more information please visit: <https://www.omgevingsvisieflevoland.nl/themas/circulaire-economie/>

Partners in the Platform Circular Flevoland are the province, municipalities regional knowledge institutes, and above all entrepreneurs. The partners exchange knowledge and can try to establish new initiatives for circular supply chains. For entrepreneurs, the platform enables setting up new business contacts. Concrete results include: starting up new projects, business development, and market introduction.

Governments involved can ask for barriers and enablers, and consequently try to develop relevant policy. Concerning the platform itself it is key to remain open for new entrants and actively connect to businesses. A major role has been identified for a so called *ketenmanager* (circular manager). A professional who is able to combine expertise about circular economy with specific knowledge of a certain industry.

## 7. Greater Manchester, UK

Greater Manchester (GM) is a geographic area in the North West of England consisting of 10 Municipalities (Local Authorities) with a population of 2.8 million people and an economy of approximately €72 billion. In addition, the 10 municipalities form part of the Greater Manchester Combined Authority (GMCA) which was created in 2011 to provide strategic oversight and direction in a number of areas attributed to the newly devolved City Region.

Greater Manchester operates within the context of national strategies and targets:

- The UK Industrial Strategy sets out the country's vision for its future economy, with one of the Key Challenges identified as Clean Growth (UK Industrial Strategy 2017).<sup>64</sup> The Clean Growth Strategy (2018) includes a number of schemes to support the UK 25 year Environment Plan (2018) which aims to encourage producers to take ownership of negative environmental impacts of their production and products and to rationalise packaging and materials formats to enable their recycling and reuse.<sup>65</sup>
- Nationally, the UK government has a vision to become a global standard setter in finance for clean growth, including, as identified in the Clean Growth Strategy (2018), the development of an Industrial Strategy Challenge Fund to build on £2.5 billion government investment in low carbon innovation.
- In addition, the UK Circular Plastic Network<sup>66</sup> supported by UK Research and Innovation, engages UK scientists and innovators to help move the country towards more circular economic and sustainable approaches to plastics through a programme of networking and knowledge-sharing events and related support activities.
- The Plastic Pact<sup>67</sup> led by the Waste and Resources Action Programme (WRAP) and the Ellen MacArthur Foundation (April 2018) focuses on increasing the recycled content of packaging by 30%, reducing SUP by along with other targets by 2025. The UK 25 Year Environment Plan also sets out commitments on waste reduction and SUP.

### Greater Manchester Policy Context

The Greater Manchester Regional Circular Economy Status Quo Report (2020) outlines the current situation regarding the development of a circular economy in the City region.<sup>68</sup>

Greater Manchester aimed to become the first UK city region to remove Single Use Plastic (SUP) by 2020 as part of a 5-year Environment Plan and its commitment to be a zero-carbon city and economy by 2038, ahead of the national target of 2050. With a powerful commitment from Andy Burnham, the elected Mayor of Greater Manchester, great emphasis on leadership is placed on

---

<sup>64</sup> UK Industrial Strategy (2017), see: <https://www.gov.uk/government/publications/industrial-strategy-building-a-britain-fit-for-the-future>

<sup>65</sup> UK Clean Growth Strategy (2017) <https://www.gov.uk/government/publications/clean-growth-strategy>. UK 25 Year Environment Plan <https://www.gov.uk/government/publications/25-year-environment-plan>

<sup>66</sup> UK Circular Plastics Network <https://www.ukcpn.co.uk/>

<sup>67</sup> The UK Plastics Pact <https://www.wrap.org.uk/content/the-uk-plastics-pact>

<sup>68</sup> Greater Manchester Regional Circular Economy Status Quo Report (MMU, 2020).

the achievement of this ambitious target. However, whilst good progress has been made through initiatives such as the Public Sector Plastic Pact and the Plastic Free Campus, a number of initiatives have been temporally delayed due to Covid 19, including the proposed ban on plastic straws and stirrers.<sup>69</sup>

A number of policy drivers can be identified in Greater Manchester that are related to circular economy, a term that until recently has been little used in favour of the term 'Sustainable Consumption and Production' in order to communicate with the widest possible audience. However, reference is now made to circular economy, for example in the GM Environment Plan, and targets being set for the achievement of circularity in Greater Manchester.

The Greater Manchester Strategy (GMS), 'Our People, Our Place' (2017),<sup>70</sup> is an overarching framework setting out a range of shared priorities for action across the city region. The GMS has a number of Strategic Priorities which include Education, Employment, Economic Development, Communities, Environment, Housing, Health and Transport, all areas which can be aligned with a desire to become circular.

The policy framework in GM around Sustainability and Climate Change has largely been facilitated and driven by the availability of the ESIF programme in GM and the existence of the Greater Manchester Low Carbon Hub to set priorities in response to the UK Climate Change Act (2008). More recently, the GM Industrial Strategy (2019)<sup>71</sup> has been adopted by the Greater Manchester Local Enterprise Partnership (GMLEP) after significant consultation with the private, public and voluntary sectors, government and residents.

Elements of the Strategy are driven by the Environment Plan for GM 2018–2024, the core policy instrument for Green Growth in GM, with specific reference to its plans to develop a circular economy in the city region. The Plan outlines 5 Policy Challenges, Policy Challenge 3 'Production and consumption of resources' is met with the aim and target 'To put Greater Manchester on a path to being a circular economy, recycling 65% of its municipal waste by 2035 and reducing the amount of waste we produce'. Table 3 below sets out how this will be achieved.

---

<sup>69</sup> See <https://plasticfreegm.com/>

<sup>70</sup> The Greater Manchester Strategy – Our People, Our Place (GMCA, 2017) <https://www.greatermanchester-ca.gov.uk/ourpeopleourplace>

<sup>71</sup> GM's Local Industrial Strategy (GMCA, 2019) <https://www.greatermanchester-ca.gov.uk/what-we-do/economy/greater-manchesters-local-industrial-strategy/>

**Table 3: Environment Plan for Greater Manchester 2018-24 Priority Areas for Intervention**

Policy challenge	Aim/Target	Priority Areas	Sub targets
3. Sustainable Production & Consumption of resources	To put GM on a path to being a circular economy, recycling 65% of its municipal waste by 2035 and reducing the amount of waste it produces	1. Producing goods and services more sustainably, moving to a circular economy	1. 50-77% reduction in industrial emissions (38% by 2025, and 50% by 2038) (with a key focus on sustainable product design, resource efficiency and sustainable procurement)
		2. Becoming more responsible consumers	2. Limit on any increase in the quantity of waste produced to 20%
		3. Managing our waste as sustainably as possible	3. Achieve a recycling rate of 65% by 2035

However, despite the existence of the Environment Plan for GM, a number of issues have been identified in the achievement of the Priority Areas of the Plan, including GM’s relatively high population density and high levels of household waste versus the current behaviour of consumers. An additional set of Actions have therefore been identified to enable their achievement, including reference to a plastic free Greater Manchester and also the need for a Resource Strategy that will set out what the transition to a circular economy means for GM businesses and consumers.

To support these objectives SUEZ operates 34 waste and recycling facilities across Greater Manchester as part of its contract with GMCA. The aims are to achieve 55% household recycling by 2025, 60% recycling across the 20 Household Waste Recycling Centres by 2021 and at least 90% diversion from landfill by 2021.

At the time of writing, Greater Manchester is also developing a Sustainable Consumption and Production (SCP) Plan to promote economic and resource productivity and increase business opportunities through innovation. The plan will be released later in 2020.

GM’s Strategic interventions are further emboldened with the Greater Manchester Local Enterprise Partnership’s commitment to ‘Build Back Better’ in response to Covid 19, which includes a commitment to launching the first City Region Clean Growth Mission in the drive to become carbon neutral by 2038.

**Funding**

The GMCA was granted devolved powers to have significant design and oversight of the city region’s €413 million European Structural and Investment Funds (ESIF) programme 2014-2020, giving it a more direct say in the prioritisation of ERDF and ESF funding in Greater Manchester. This

power has enabled the Authority to align other resources in its GM EU Investment Plan to maximise the strategic allocation of funds and strengthen the impact on target GMS priorities.

Resourcing the Plan's activities is now a major focus. Without Brexit, the focus would currently be on the development of the 2021-2027 ESIF programme, or equivalent, and the prioritisation of the Programme's funding in GM. The Resource Strategy for the GMEP is still pending, requiring the development of a national waste strategy before its completion and adoption.

A Shared Prosperity Fund has been proposed to replace the ESIF programme for England, however, little detail is still currently available with regards to the Fund's management arrangements, size and scope and timing of the new replacement programme.

Uncertainties therefore around replacement funds for Greater Manchester post Brexit are posing a significant challenge for policy makers and practitioners alike going forward. However, there are a number of funded programmes and services available that could be used currently to support the transition to a circular economy including measures to target plastic waste. The current 2014-2020 ESIF programme is still available for live projects up until June 2023 and a number of other programmes, specific to the promotion of circularity, are available for companies and stakeholder organisations to access to aid the transition to a circular economy.

### **Best practices**

A number of funding initiatives have been identified to support activity relating to the circular economy and Plastic waste, including those funded by the Greater Manchester ESIF Programme 2014-2020 and a wider range of initiatives available at national level. The next part elaborates on three regional best practices in the field of plastic waste.

#### **7.1 Best practice 1 – Additive Manufacturing Pilot Plant**

The €1.9 million pilot plant will enable the material testing of the high value (PET / HDPE / PP / LDPE) providing a testing platform for the use of recycled plastic material into AM (3D printable) filament. The end users will benefit from this as they will have access to unique, never developed waste plastic filaments and will use this as an alternative / substitute to virgin plastic feedstock. The pilot plant was chosen by the consortium to be led by MMU due to their expertise in AM/3D printing and AM feedstock production and have shown these to be feasible on small scales.

The Plant will be based in Runcorn and will benefit from the collection of all types of SUP from one single waste stream, in the UK, Netherlands, Germany and Belgium and the UK plant will focus on "low volume-high value" use, thus covering a wide range of products and markets whilst still collecting and recycling the (almost) full stream of municipal SUP.

At the end of the three years, the pilot plant will have not only have diverted 80 tonnes from the 4 partner countries of single use plastic (single stream PET, PP, LDPE and HDPE) from EfW/landfill, but will also transform this plastic waste (upscaling it) into useful and more AM feedstocks for use in new or existing products. Furthermore these AM feedstocks comprised of municipal SUP will be enriched for use in sophisticated applications and new or existing products.



At the end of the project, the AM plant will be run by MMU and Viridor. Investment will be sought to re-new the plant and a business plan will be written to ensure investment is secured to duplicate the AM plant in other NEW regions.

## **7.2 Best Practice 2 – North West of England Circular Economy Hub**

The NW of England Circular Economy Hub is an interdisciplinary and collaborative Centre exploiting world leading interdisciplinary research to directly support SMEs, led by Manchester Metropolitan University (MMU) and supported by academic institutions across the North West of England alliance. The CE-Hub aims to be pioneering initiative to drive a circular economy transition across the North of England enabling SMEs and enterprises across the North of England to realise the benefits of transitioning from the existing linear model of 'Take, Make, Use, Dispose' to a more circular approach, where materials and products are kept at their highest resource value for as long as possible.

The consortia have demonstrable experience of interdisciplinary working and have a track record of working in close partnership with multi-nationals and SMEs. MMU has relationships with over 1000 SMEs across the North West, through research and business development programmes - we will exploit these relationships to ensure that the project is both steered by SME needs and works to produce real world business impact. The hub will work closely with key industry partners, local government, charities and a variety of key packaging stakeholder groups ensuring that activities are shaped by real world challenges requiring innovative solutions; we will bring research directly to businesses at the forefront of developing the CE.

## **7.3 Best Practice 3 – Plastic to Hydrogen Facility, Protos**

Peel Environmental – part of Peel L&P – and Waste2Tricity have received planning consent from Cheshire West & Chester Council for the UK's first waste plastic to hydrogen facility at the 54-hectare Protos site near Ellesmere Port. The £7m development will see 14 full time permanent jobs created at Protos with over 100 jobs created in the North West during fabrication and construction.

It will transform how plastic waste is dealt with in the region, treating up to 35 tonnes of unrecyclable plastics a day and using it to create a local source of hydrogen. This hydrogen could be used as a clean fuel for buses, Heavy Goods Vehicles (HGVs) and cars, helping to reduce air pollution and improve air quality on local roads.

The facility will also generate electricity which could be provided to commercial users via a microgrid at Protos, helping to reduce reliance on fossil fuels. Peel Environmental is looking at developing a closed loop solution at Protos where plastics are recycled on-site with the leftover material used to create hydrogen.

A start on site is expected in Autumn 2020 with the facility due to be operational in 2021. Last year it was announced that Peel Environmental had signed a Collaboration Agreement with Waste2Tricity and PowerHouse Energy to develop a total of 11 waste plastic to hydrogen facilities across the UK, representing an investment of £130 million.

## 8. Conclusion

The regional reports make clear that each of the participating regions is investing in a circular economy for plastics. These regional strategies become apparent in documents such as the *Walloon Plan of Waste-Resources*, the *Greater Manchester Strategy*, *Omgevingsvisie Flevoland* and *Abfallwirtschaftsplan Rheinland-Pfalz*. In general the policies set out in these documents are in line with or go beyond the *European Strategy for Plastic in a Circular Economy* from the European Commission and targets from the Sustainable Development Goals. For example to be able to recycle or reuse two thirds of municipal waste, or to 'be fully circular 2050'.

Different instruments and regulations have been established to obtain the policy objectives set and to develop a circular economy (for plastics). This report presents 12 best practices, three from each region. In this short conclusion some overall findings from these policies are being described, from the point of view of the template presented in table 1: technology push, demand pull and policies at a systemic level.

### Technology push

Several instruments have been highlighted that try to stimulate circular strategies for plastic manufacturers, such as better use of plastic resources, recycling, substitutes and product life-time extension. The stimulus predominately involved stimulation of information exchange, cooperation and R&D investments. Notable are the two examples that are part of the TRANSFORM-CE project: *Circular Plastic Factory* and *Additive Manufacturing Pilot Plant*; and plastic to *Hydrogen Facility*. What is interesting about a Walloon example, *Tertre Industrial Zone*, is the objective to also create an ecosystem of companies.

### Demand pull

Demand pull policy instruments are generally being seen as influential. They involve all kind of instrument that stimulate the demand of, in this case, products from circular plastics, such as through: taxes, public procurement, standards, prohibitions, labeling or information campaigns. Besides, countries and regions have set specific targets to buy circular goods. Examples from Germany and the Netherlands make clear that especially green or circular public procurement is getting more attention in governments. It leads to interesting examples. Though, unclear is still what the impact of these actions are and what is needed to reach the regional targets.

### Systemic

Taken into account the complex nature of stimulating a circular economy, it is not surprising that many policy instruments are at a systemic level. Instruments identified for this document include establishing networks of businesses and other stakeholder involved or wanting to be involved in circular economy activities: circular economy hubs or platforms, or local ecosystems. Other instruments focus on information exchange or education of, for example, Circular Economy Facilitators as a kick starter for circular innovation. A notable example is a private initiative for a voluntary return system for old plastic PVC profiles, involving producers, suppliers, building companies, demolition companies, waste management companies and governmental partners.

## References

References are made in footnotes in the text. An overview of the major sources can also be found here.

- Borrás, S. & Edquist, C. (2013). The choice of innovation policy instruments. *Technological Forecasting & Social Change*, 8, pp. 1513-1522.
- EC. (2018). *A European Strategy for Plastics in a Circular Economy*. Brussels: European Commission.
- EC. (2019). *The European Green Deal*. European Commission. Available from: <https://eur-lex.europa.eu/legal-content/EN/TXT/?qid=1576150542719&uri=COM%3A2019%3A640%3AFIN>. [Accessed 3 February 2020].
- Eurostat. (2017). *Sustainable Development in the European Union – Monitoring report on progress towards the SDGs in an EU context (2017 edition)*. Luxembourg: Publications Office of the European Union.
- Frenken, K. & Hekkert, M.P. (2017). Innovatiebeleid in tijden van maatschappelijke uitdagingen. *Essaybundel "Sturen in een verweven dynamiek" - Perspectieven op complexiteit en oriëntaties voor beleid* (pp. 46-57). Den Haag: Ministerie van Economische Zaken.
- HM Government. (2017). *Industrial Strategy – Building a Britain fit for the future*. Retrieved from: <https://www.gov.uk/government/publications/industrial-strategy-building-a-britain-fit-for-the-future>
- HM Government. (2017). *The Clean Growth Strategy – Leading the way to a low carbon future*. Retrieved from: <https://www.gov.uk/government/publications/clean-growth-strategy>
- HM Government. (2017). *A Green Future: Our 25 year plan to improve the environment*. Retrieved from: <https://www.gov.uk/government/publications/25-year-environment-plan>
- IPO, Unie van Waterschappen, VNG. (2017). *Naar een duurzaam Nederland*. Den Haag: IPO, Unie van Waterschappen, VNG
- Knol, E. & Velzing, E.-J. (2019). *Learning communities for MMIP's – Een schakel voor versnelling en opschaling*. Ommen: Bureau Qeam.
- Mazzucato, M. (2018) *Mission-Oriented Research & Innovation in the European Union – A problem-solving approach to fuel innovation-led growth*. Available from: [https://ec.europa.eu/info/sites/info/files/mazzucato\\_report\\_2018.pdf](https://ec.europa.eu/info/sites/info/files/mazzucato_report_2018.pdf). [Accessed 3 February 2020]
- MinIM & MinEZ. (2016). *Nederland Circulair in 2050*. Retrieved from: <https://www.rijksoverheid.nl/onderwerpen/circulaire-economie/documenten/rapporten/2016/09/14/bijlage-1-nederland-circulair-in-2050>
- MinIM & MinEZ, (2019). *Uitvoeringsprogramma Circulaire Economie 2019-2023*. Retrieved from: <https://www.rijksoverheid.nl/onderwerpen/circulaire-economie/documenten/rapporten/2019/02/08/uitvoeringsprogramma-2019-2023>
- Omgevingsvisie Flevoland. (2019). *Circulair inkopen in Flevoland*. Retrieved from: <https://www.omgevingsvisieflevoland.nl/actueel/circulair-inkopen-in-flevoland/>
- Parlement Wallon. (2019). *Résolution – visant à soutenir le développement de l'économie circulaire en Wallonie*. 1330 (2018-2019) – no 3, 3 Mai 2019.
- Provincie Flevoland. (s.d.). *Omgevingsvisie Flevoland Straks*.
- Provincie Flevoland. (2019). *Samen maken we Flevoland – Uitvoeringsagenda deel 1*. Lelystad: Provincie Flevoland.
- Provincie Utrecht. (2018). *De Nieuwe Utrechtse Stijl*. Utrecht: Provincie Utrecht.

Rogge, K. S., & Reichardt, K. (2016). Policy mixes for sustainability transitions: An extended concept and framework for analysis. *Research Policy* 45 (8), pp. 1620-1635.  
<https://doi.org/10.1016/j.respol.2016.04.004>

TRANSFORM-CE. (2019). *INTERREG NWE project proposal - TRANSFORMing single use plastic waste into additive manufacturing and intrusion-extrusion moulding feedstocks and creating a new Circular Economy model for NWE.*

Transitie-agenda Kunststoffen. (2018). *Transitie-agenda Circulaire Economie – Kunststoffen.*  
Retrieved from: <https://www.rijksoverheid.nl/onderwerpen/circulaire-economie/documenten/rapporten/2018/01/15/bijlage-3-transitieagenda-kunststoffen>

UN. (2015). *Transformer notre monde : le Programme de développement durable à l'horizon 2030.*  
Nations Unies, Résolution adoptée par l'Assemblée générale le 25 septembre 2015.

Velzing, E-J. (2013). *Innovatiepolitiek.* Delft: Eburon

## About the project

The problems associated with plastic waste and in particular its adverse impacts on the environment are gaining importance and attention in politics, economics, science and the media. Although plastic is widely used and millions of plastic products are manufactured each year, only 30% of total plastic waste is collected for recycling. Since demand for plastic is expected to increase in the coming years, whilst resources are further depleted, it is important to utilise plastic waste in a resourceful way.

TRANSFORM-CE aims to convert single-use plastic waste into valuable new products. The project intends to divert an estimated 2,580 tonnes of plastic between 2020 and 2023. Two pilot plants will be set up, one in Almere (NL) and one in the UK. The plants will make use of two innovative technologies – intrusion-extrusion moulding (IEM) and additive manufacturing (AM) – to turn plastic waste into recycled feedstock and new products.

Moreover, the project will help to increase the adoption of technology and uptake of recycled feedstock by businesses. This will be promoted through research into the current and future supply of single-use plastic waste from municipal sources, technical information on the materials and recycling processes, and circular business models. In-depth support will also be provided to a range of businesses across North-West Europe, whilst the insights generated through TRANSFORM-CE will be consolidated into an EU Plastic Circular Economy Roadmap to provide wider businesses with the 'know-how' necessary to replicate and up-scale the developed solutions.

### Lead partner organisation

Manchester Metropolitan University

### Partner organisations

Materia Nova  
Social Environmental and Economic Solutions (SOENECS)  
Ltd  
Gemeente Almere  
Save Plastics  
Technische Universiteit Delft  
Hogeschool Utrecht  
Hochschule Trier Umwelt-Campus Birkenfeld Institut für  
angewandtes Stoffstrommanagement (IfaS)  
bCircular GmbH  
Viridor Waste Management Limited

### Countries

UK | BE | NL | DE

### Timeline

2019-2023